

Starting with a Clean Slate: Technology-Neutral, All-Hazards Safety Assessment for Fusion



Andrew Sowder, Ph.D., CHP
Sr. Technical Executive, Fusion Energy

Organization of Agreement States 2025 Annual Meeting
August 12, 2025

Fusion Plant: More Radiological/Industrial than Nuclear

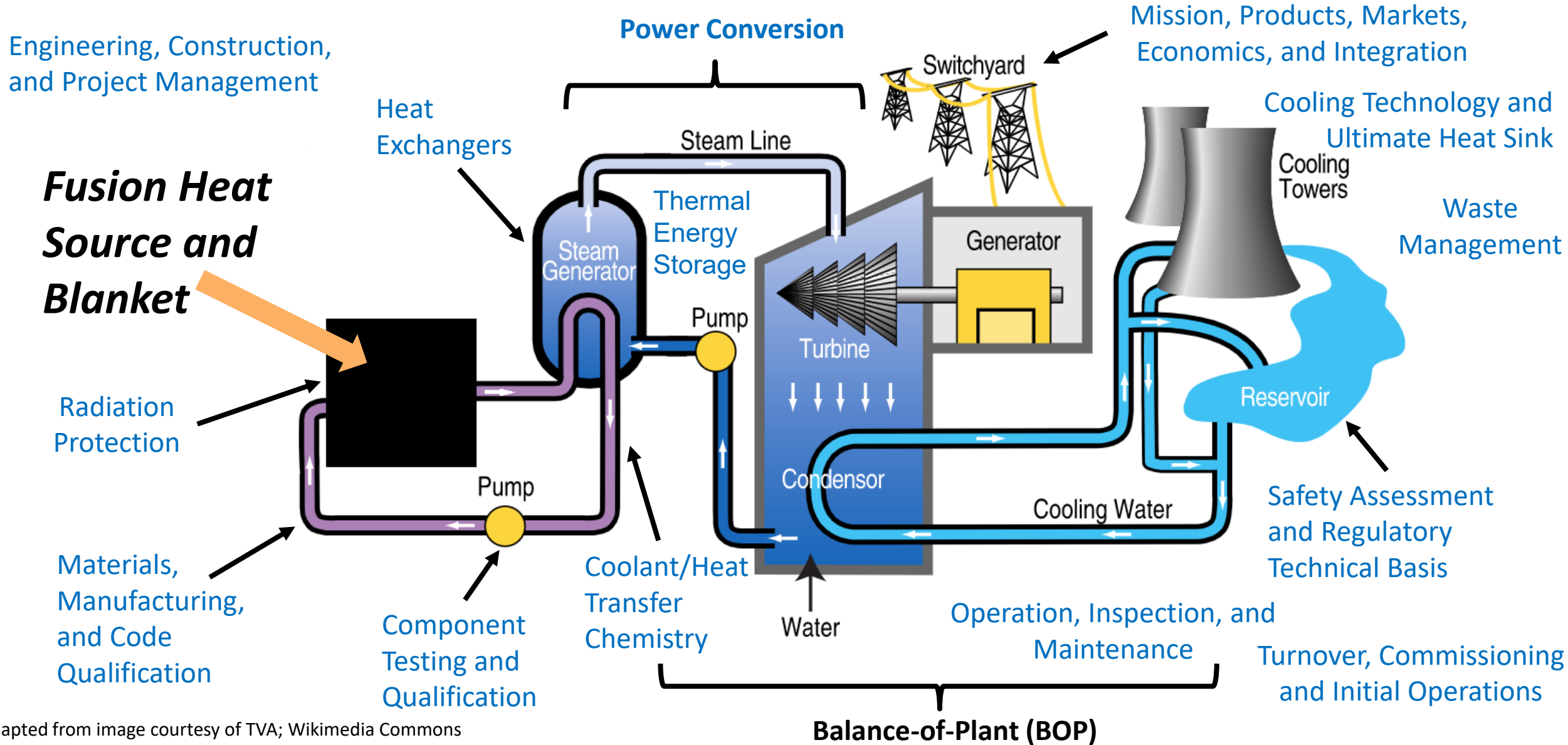

Adapted from image courtesy of TVA; Wikimedia Commons

Case for a Tech-Neutral, All-Hazards Approach to Fusion Safety

- Starting with a technology-neutral, all-hazards approach reduces likelihood of “unduly limiting”¹ opportunities to realize the benefits of fusion
- Repurposing industry-specific risk and safety paradigms with embedded assumptions and motives likely to bring legacy burdens and implicit biases
 - Offsite radiological hazards are not necessarily dominant safety concern for fusion
 - Probabilistic Risk Assessment (PRA) for nuclear power originated in efforts to quantify likelihood of major/severe nuclear accidents² that do not apply to fusion
- Established methods and experience from non-nuclear industrial activities may offer more appropriate, balanced approaches for evaluating fusion energy hazards and consequences based on relevant:
 - Missions: heat and electricity generation
 - Scales and complexity: chemical processing
 - Hazards: high voltage, cryogenic, magnetic fields and stored energy, vacuum, radiological, and dust

¹IAEA Fundamental Safety Principles (SF-1). November 2006, STI/PUB/1273.

²Theoretical Possibilities and Consequences of Major Accidents in Large Nuclear Power Plants. U.S. Atomic Energy Commission. March 1957. WASH-740.

The Importance of Knowing Your Enemy

Nine lost their lives in Graniteville train derailment

BY LARRY WOOD LWOOD@AIKENSTANDARD.COM
JAN 6, 2020

Aiken Standard
Aiken County, South Carolina's trusted source for news and information since 1867

Deadly SC train crash, 20 years later. Scars remain as small town tries to forge ahead.

BY CARL DAWSON CDAWSON@AIKENSTANDARD.COM
JAN 6, 2025

Damage to the equipment in Avondale Mills' Gregg Plant led to layoffs. In the summer of 2006, the company stopped operations. There were 4,000 jobs lost in four states, including 1,500 in Graniteville.



https://www.postandcourier.com/news/graniteville-sc-2005-train-derailment-nine-killed/article_e271687a-c9ef-11ef-801f-83adde22668a.html

6 Poultry Workers Died From A Nitrogen Leak. OSHA Has Issued \$1 Million In Fines

JULY 23, 2021 · 3:50 PM ET

HEARD ON WEEKEND EDITION SATURDAY



Andrea Hsu

Workers had just begun their shift at the Foundation Food Group plant in Gainesville, Ga., when a freezer malfunctioned, releasing colorless, odorless nitrogen into the air, according to the Labor Department. The liquid nitrogen is used to freeze chicken. Six workers died of asphyxiation.

<https://www.npr.org/2021/07/23/1019784347/six-poultry-workers-died-from-a-nitrogen-leak-osha-has-issued-1-million-in-fines>

Process Hazard Analysis (PHA) from Chemical Industry^{1,2}

- December 3, 1984, Bhopal, India: Early morning gaseous release of methyl isocyanide resulted in >3,000 deaths and >100,000 injuries (exact figures are not known).
 - Worst process chemical accident on record.
 - Exposed lack of a formalized process safety mindset, assessment methods and tools, and resources.
- In response, the American Institute of Chemical Engineering (AIChE) established Center for Chemical Process Safety (CCPS) in 1985 to promote process safety and prevent future catastrophic incidents.
 - AIChE published first process safety guideline book, Guidelines for Hazard Evaluation Procedures, in 1987.

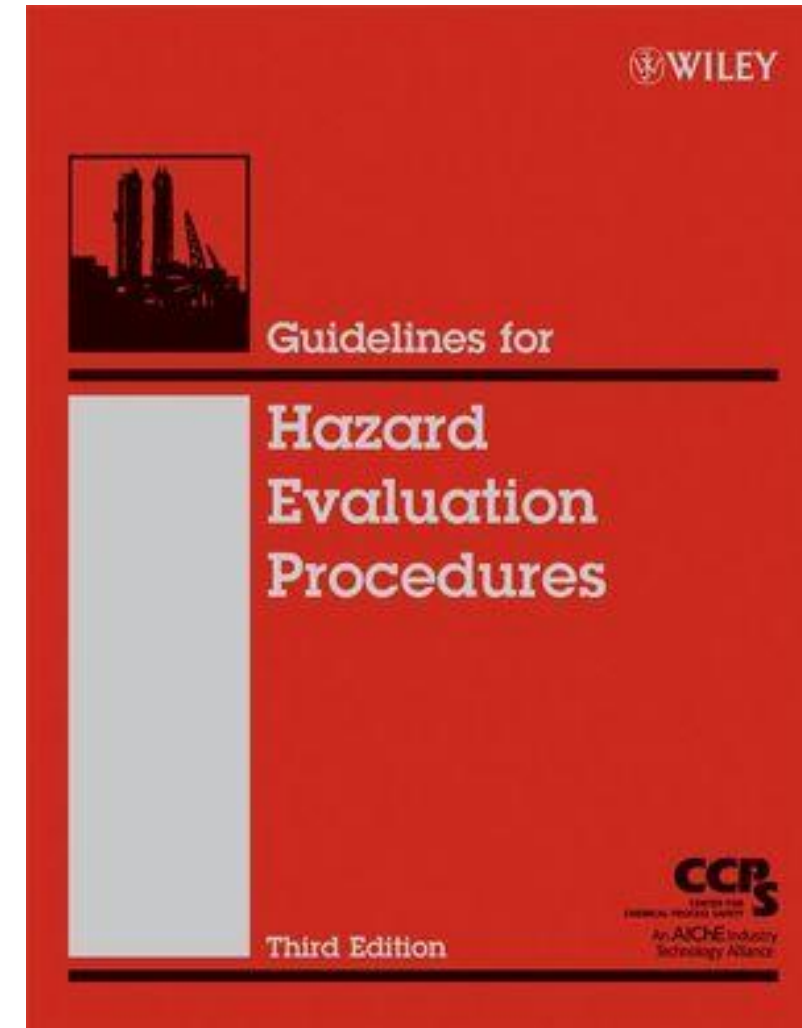

¹AIChE Center for Chemical Process Safety (CCPS). History. <https://www.aiche.org/ccps/history>

²UK Health & Safety Executive. Union Carbide India Ltd, Bhopal, India. 3rd December 1984. <https://www.hse.gov.uk/comah/sragtech/caseuncarbide84.htm>

PHA: Foundation for EPRI's Safety-in-Design (SiD) Methodology

- PHA intended to identify and evaluate process hazards for the purpose of determining the adequacy of or need for control measures.¹
- Most PHA methods focus on two questions from the Risk Triplet (in bold)
 - **What can go wrong?**
 - How likely is it?
 - **What are the consequences?**
- **Diversity of PHA methods allows for flexible and iterative application as design matures.**
- Application of PHA is a standardized practice across many industries.
 - OSHA 29 CFR Part 1910.119: Process Safety Management of Highly Hazardous Chemicals; Explosives and Blasting Agents (PSM Rule)
 - ISO 31000 Risk Management Series (and associated standards)
 - DOE-STD-1189-2016: Integration of Safety into the Design Process
 - DOE-STD-1628-2013: Development of Probabilistic Risk Assessments for Nuclear Safety Applications
 - ANSI/ASME/ANS RA-S-1.4-2021: Probabilistic Risk Assessment Standard for Advanced Non-Light Water Reactor Nuclear Power Plants
 - NUREG-1513: Integrated Safety Analysis Guidance Document
 - NUREG-1520: Standard Review Plan for the Review of a License Application for a Fuel Cycle Facility

¹DOE Handbook: Chemical Process Hazards Analysis. August 2004. DOE-HDBK-1100-2004.

<https://www.standards.doe.gov/standards-documents/1100/1100-BHdbk-2004/@@images/file>

Diverse PHA Methods Enable Fit-for-Purpose SiD Application

From the AIChE CCPS Guidelines:

- Preliminary Hazard Analysis
- Safety Review
- Relative Ranking
- Checklist Analysis
- What-If Analysis
- Chemical Interaction Matrix
- What-If/Checklist Analysis
- Hazard and Operability (HAZOP) Study
- Failure Modes and Effects Analysis (FMEA)
- Fault Tree Analysis (FTA)
- Event Tree Analysis (ETA)
- Cause-Consequence Analysis

Other Examples (among many):

- Functional Failure Modes and Effects Analysis (FFMEA)
- Systems Theoretic Process Analysis (STPA)
- Master Logic Diagram (MLD)
- Initiating Event Literature Survey
- Layer of Protection Analysis (LOPA)

PHA methods in blue have been applied in prior evaluations by EPRI and/or Vanderbilt University research teams.

ASME Plant Systems Design Standard PSD-1 (under development)

- Integrates best practices for modern design of any plant/facility with hazards

- Addresses three activities:
 1. **Conduct plant process hazard evaluations and analysis in the early phases of design** that:
 - Provide early identification of hazards, including strategies to avoid and mitigate them
 - Advance as the design matures
 - Provide structure for the development of a quantitative risk assessment (if needed)
 2. **Incorporate and integrate systems engineering design processes, practices, and tools** with traditional architect engineering design processes, practices, and tools
 3. Integrate probabilistic design processes, practices, and tools with traditional deterministic design processes using reliability and availability targets

EPRI SiD Methodology

Notional hierarchy with indicative methods. Assessment methods are NOT fixed; others can be (and have been) applied as needed or appropriate.

*Qualitative
minimal design
information*

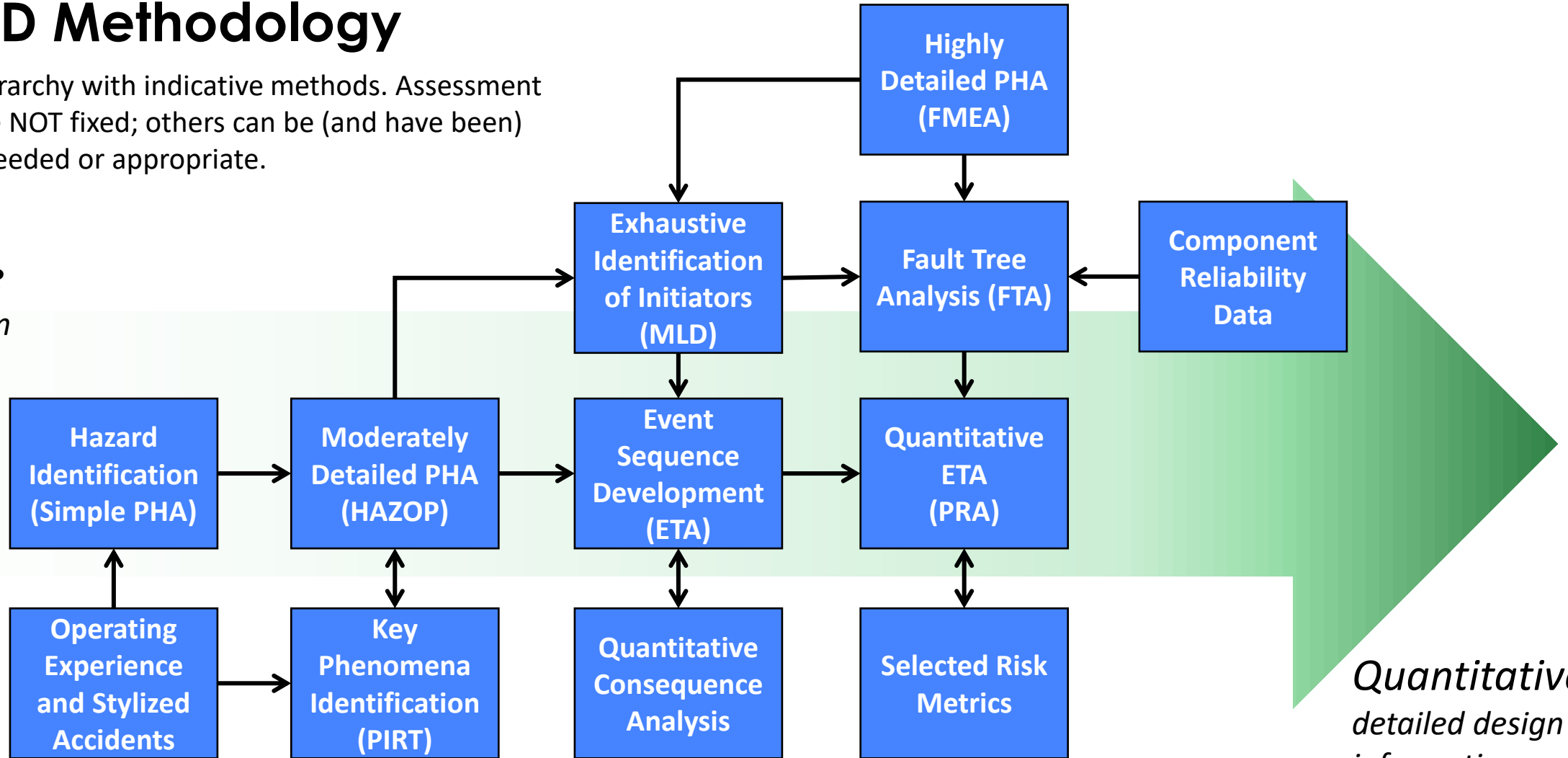

*Quantitative
detailed design
information*

PHA – Process Hazards Analysis	FTA – Fault Tree Analysis	PRA – Probabilistic Risk Assessment
FMEA – Failure Modes and Effects Analysis	HAZOP- Hazards and Operability [study]	PIRT – Phenomenon Identification and Ranking Table
MLD – Master Logic Diagram	ETA – Event Tree Analysis	

EPRI SiD Methodology

Notional hierarchy with indicative methods. Assessment methods are NOT fixed; others can be (and have been) applied as needed or appropriate.

 = fully quantitative

*Qualitative
minimal design
information*

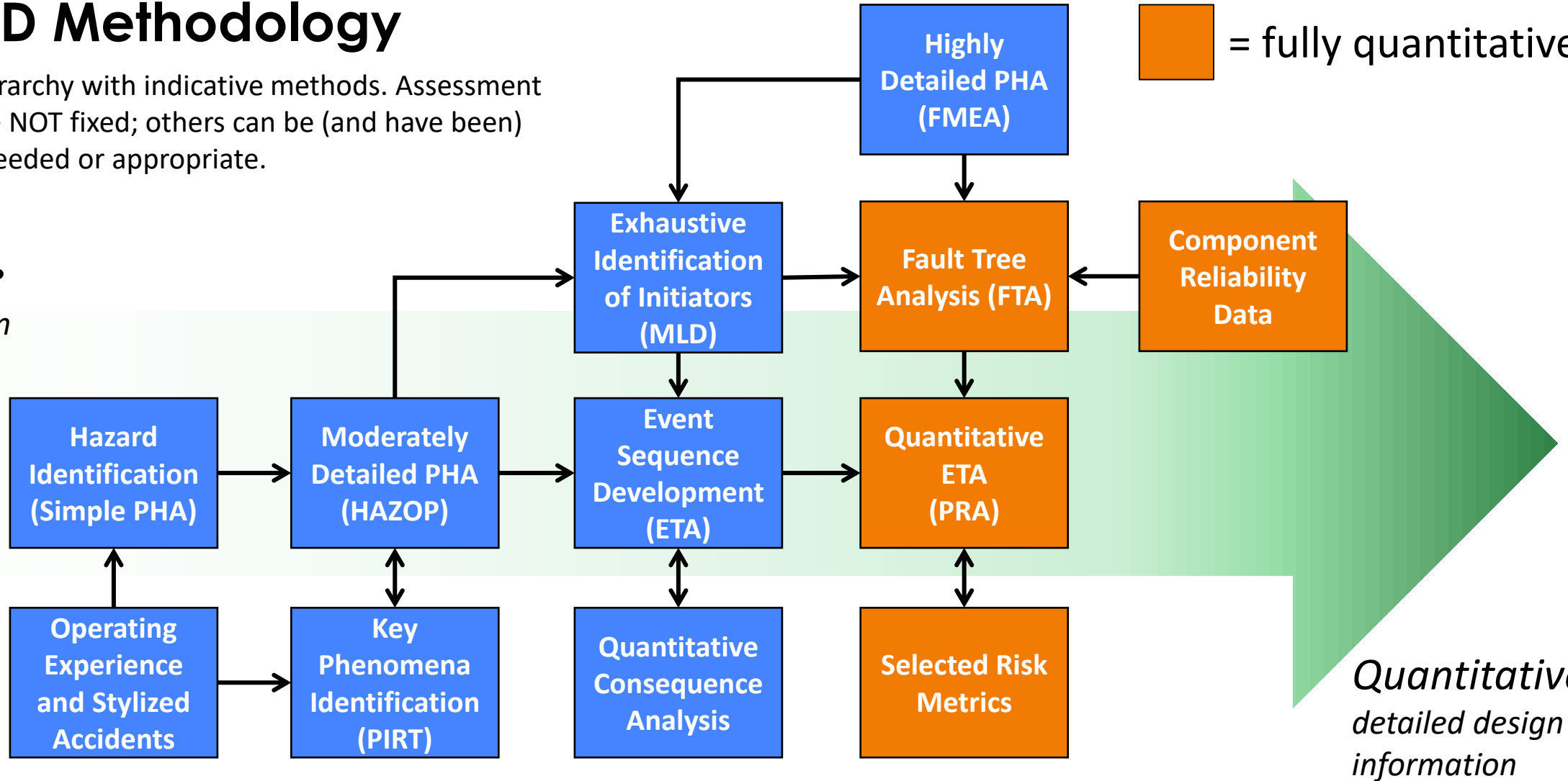

*Quantitative
detailed design
information*

PHA – Process Hazards Analysis	FTA – Fault Tree Analysis	PRA – Probabilistic Risk Assessment
FMEA – Failure Modes and Effects Analysis	HAZOP- Hazards and Operability [study]	PIRT – Phenomenon Identification and Ranking Table
MLD – Master Logic Diagram	ETA – Event Tree Analysis	

EPRI SiD Methodology

Notional hierarchy with indicative methods. Assessment methods are NOT fixed; others can be (and have been) applied as needed or appropriate.

*Qualitative
minimal design
information*

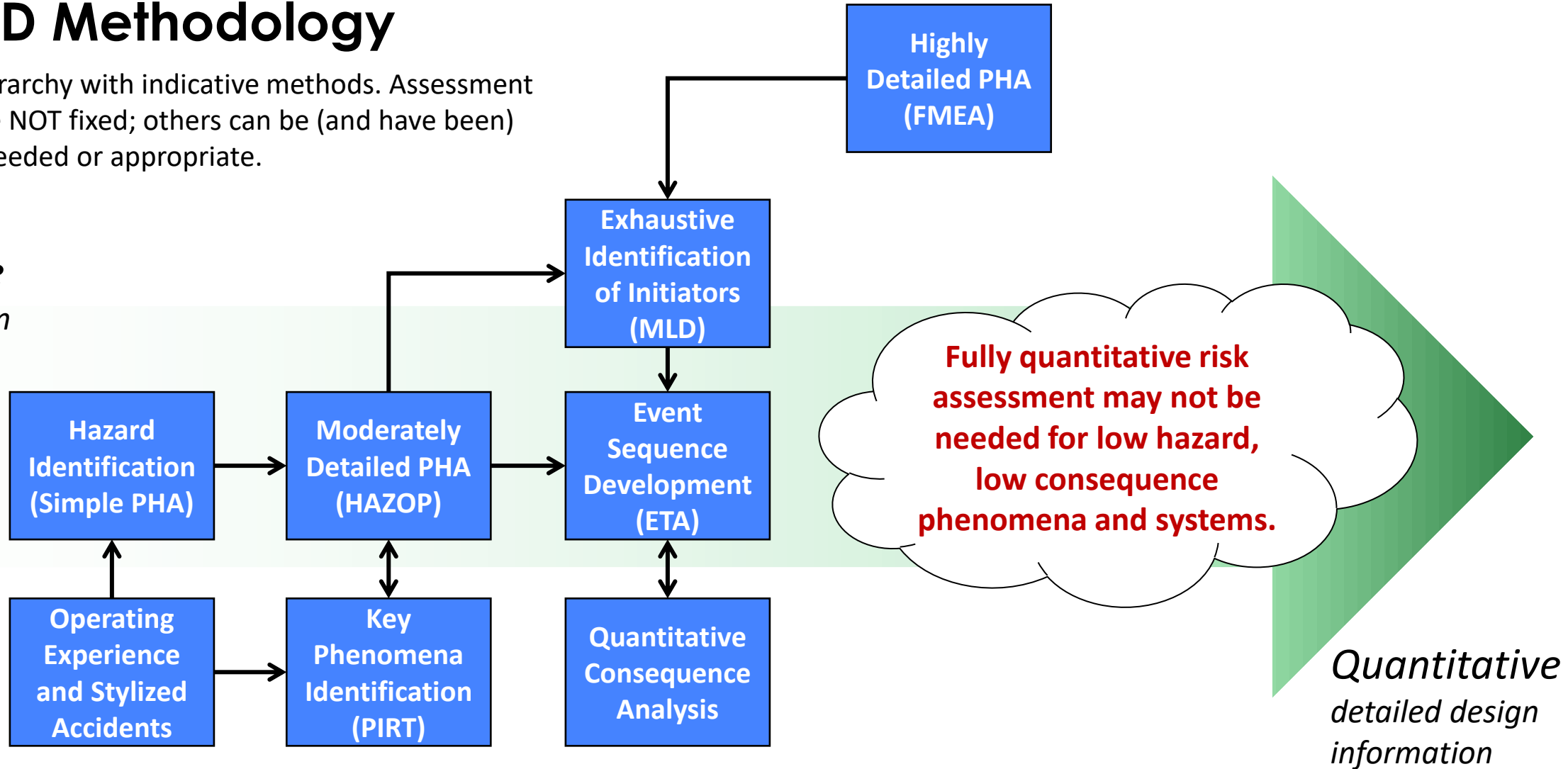

PHA – Process Hazards Analysis

FTA – Fault Tree Analysis

PRA – Probabilistic Risk Assessment

FMEA – Failure Modes and Effects Analysis

HAZOP- Hazards and Operability [study]

PIRT – Phenomenon Identification and Ranking Table

MLD – Master Logic Diagram

ETA – Event Tree Analysis

SiD Integration with Model-Based Systems Engineering (MBSE)*

Iteration as design matures supports early identification of issues when changes are least costly and impactful.

Key

- C/PC: Conceptual/Pre-Conceptual design
- IROFS: Items Relied On For Safety
- ISA: Integrated Safety Analysis
- QRA: Quantitative Risk Assessment
- PSSR: Pre-Startup Safety Review
- WI: What-If? Analysis
- FFMEA: Functional Failure Modes & Effects Analysis
- HAZOP: Hazards and Operability Analysis
- FMEA: Failure Modes and Effects Analysis
- MLD: Master Logic Diagram
- FTA: Fault Tree Analysis
- Qual/Quant: Quantitative/Qualitative analysis
- BA/BR: Bounding Accident/Bounding Release
- ST: Source Term Estimate
- MST: Mechanistic Source Term
- ETA: Event Tree Analysis
- R&U: Reliability & Uncertainty

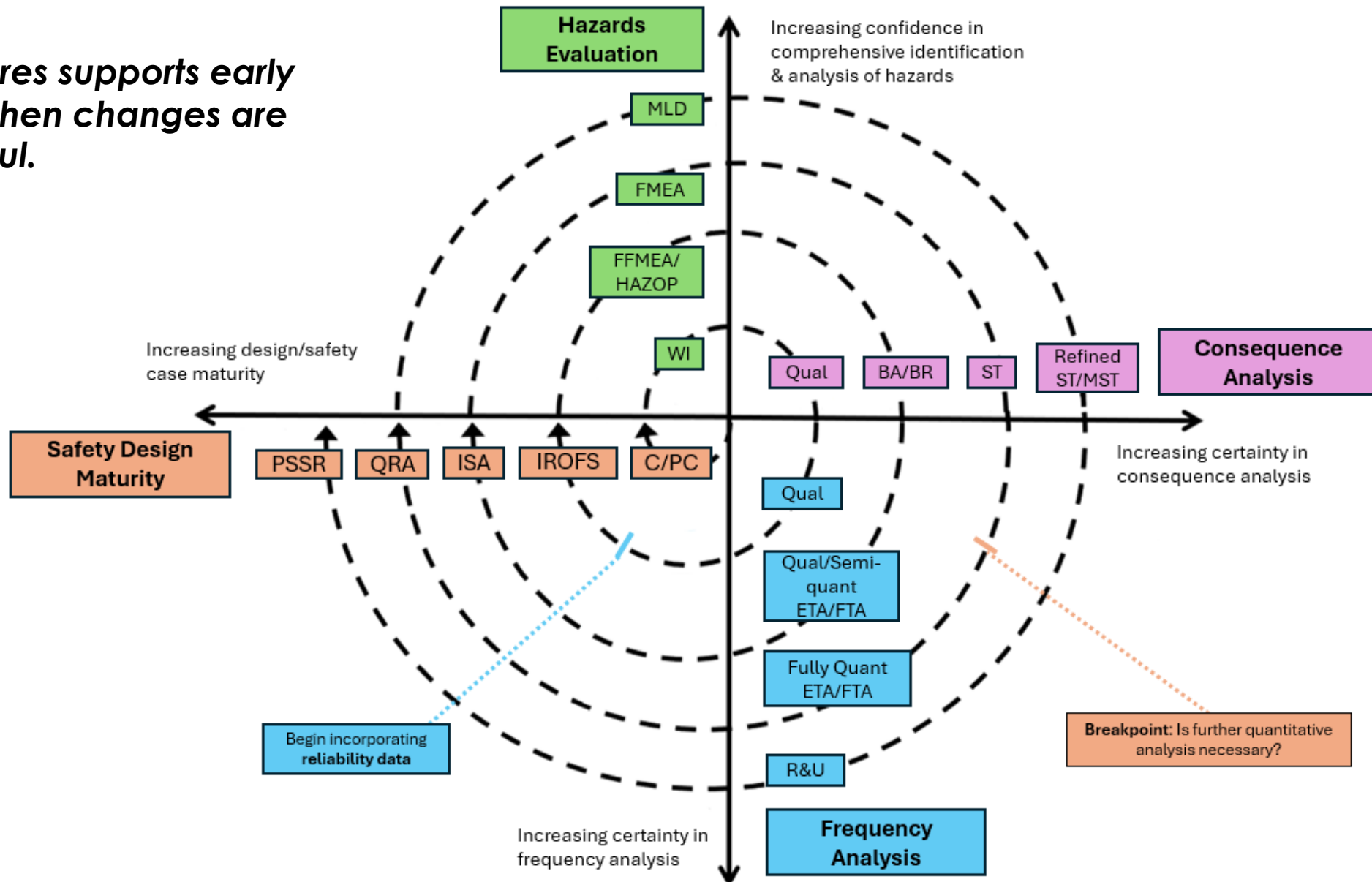

*EPRI is sponsoring work with Vanderbilt University integrating SiD with MBSE using SysML.

Chronology of EPRI SiD Application to Commercial Systems



Present: Application of SiD to Fusion

July 2022-Present: General Atomics Fast Modular Reactor (FMR) SiD Design

October 2022-Present: TerraPower Molten Chloride Fast Reactor (MCFR) Design

February 2021: Hybrid SiD Approach to Support Moltex Stable Salt Reactor Design

June 2019: Hazard and Operability Study (HAZOP) of Kairos Power Forced Convection Loop (FCL-2)

October 2015: What-If Analysis of FLiBe Energy Liquid Fluoride Thorium Reactor (LFTR)

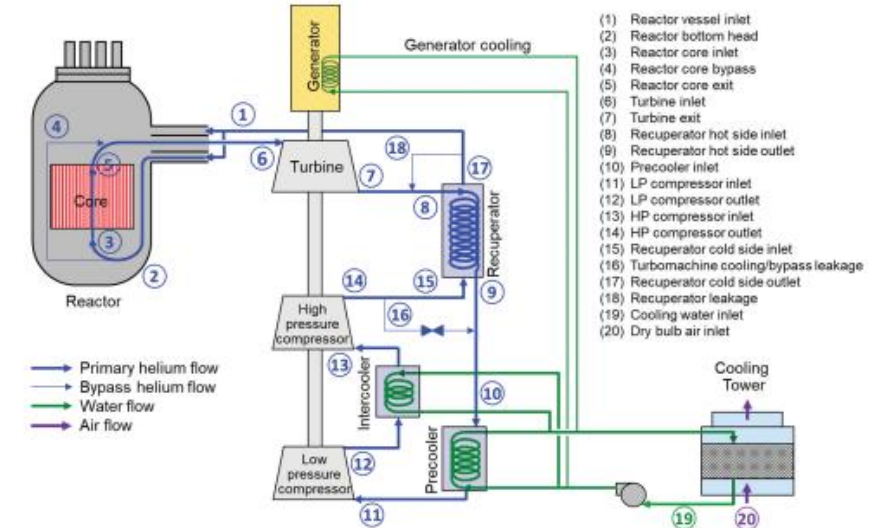

Image Credit: Choi et al., (2024). Progress in Fast Modular Reactor Conceptual Design, Nuclear Technology.

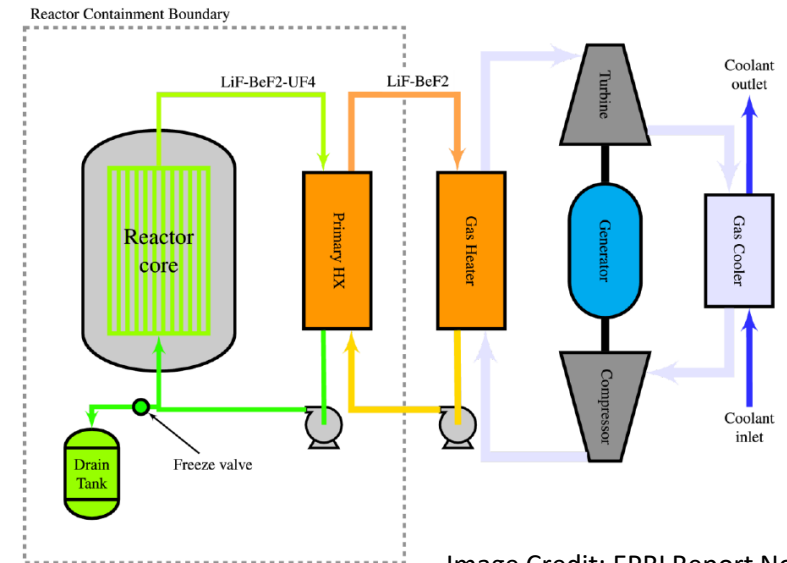

Figure 2-1 Reference LFTR design schematic [Flibe Energy, 2015].

Image Credit: EPRI Report No. 3002005460

Applying SiD to Fusion Energy Applications

- **Motivation:** Safety-in-Design offers a fit-for-purpose, “clean slate” approach for fusion energy technology assessment
 - Novel and diverse designs
 - New (different) safety concerns and magnitudes
 - New systems/components and reliability concerns
 - Lack of operating experience of key systems and components in an integrated plant
- **First EPRI fusion product: Fusion SiD Body of Knowledge (BoK):** Curated summary of relevant work and experience to be published in 2025
 - BoKs are a common approach for documenting the state-of-the-art in a technical field
 - Provides an accessible compilation of technical information for early safety and design efforts and stakeholder engagement
 - Forms a technical basis for applying SiD to fusion power plants

Key Takeaways

- Fundamental differences between fusion and other technologies (e.g., fission) warrant a “clean slate” approach; embedded assumptions and mindsets may persist for safety paradigms developed for incumbent technologies
- Existing international, standardized, technology-neutral PHA (and supporting) tools and methods offer a structured, fit-for-purpose way to implement a “clean slate” approach for fusion
- EPRI is pursuing and performing case studies with private sector developers to demonstrate utility of and improve SiD for fusion applications. Join us!

Acknowledgements

- Inspiration by, leadership of, and collaboration with Professor Steve Krahn and his research team in Vanderbilt University's Department of Civil and Environmental Engineering .
- In-kind support from and collaborations with many organizations, including:
 - Southern Company
 - Kairos Power
 - General Atomics
 - FLiBe Energy
 - Oak Ridge National Laboratory
 - B. John Garrick Institute for the Risk Sciences at the University of California Los Angeles
- Funding support from EPRI, Southern Company, U.S. Department of Energy Office of Nuclear Energy, and the Advanced Research Projects Agency–Energy (ARPA-E)

Appendix: Prior Demonstration of SiD Application to Advanced Fission Energy Systems

and

References

A Decade of EPRI Development & Application of SiD

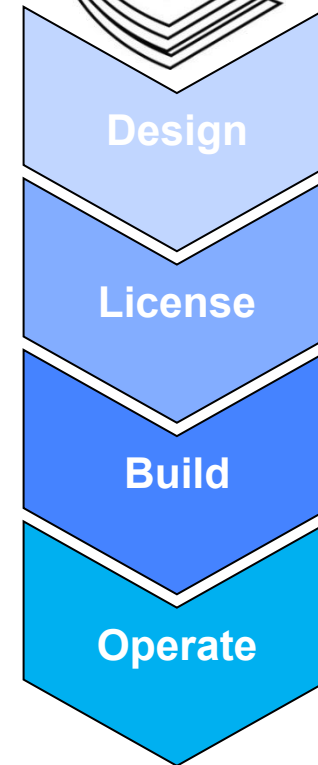

- ✓ Motivated by the challenges faced by advanced fission developers in creating a safety case for technologies that may have limited to no commercial operating experience; incorporate novel structures, systems, and components (SSCs); and present unique source terms
- ✓ Assembled a methodology to facilitate early integration of safety assessment the design of advanced (fission) reactors
- ✓ Produced a body of knowledge (BoK) on application of relevant process hazard analysis (PHA) methods for advanced reactor designs
- ✓ Illustrated application of approach with historical and unique Molten Salt Reactor Experiment (MSRE) case studies
 - supported Licensing Modernization Project via MSR “table-top” exercise
 - briefed to USNRC staff and Advisory Committee on Reactor Safeguards (ACRS)
- ✓ Demonstrated utility via pilot applications with advanced reactor developers

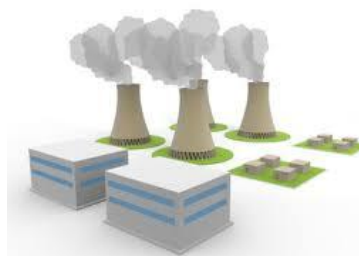

Documentation of development and application for ARs is publicly available.

Full (Retrospective) Exercise of EPRI SiD Methodology on the Historical Molten Salt Reactor Experiment (MSRE) Design

	Operating Experience and Stylized Accidents	Hazard ID	Key Phenomena Identification	HAZOP Study	Event Sequence Development	Quantitative Consequence Analysis	FMEA	FTA	Component Reliability Data	Quant. ETA	Risk Metric Selection
Off-Gas System and Component Cooling System	✓	✓	✓	✓	✓	✓		✓	✓	✓	✓
Fuel Salt Loop	✓	✓	✓	✓	✓						✓
Freeze Valve	✓						✓	✓	✓		
Fuel Processing System	✓	✓	✓	✓	✓						✓

Details for this matrix can be found in Table 1-1, "Roadmap to technical work for MSRE Case Study (EPRI Report 3002018340)

References (1 of 3)

- EPRI Reports
 - EPRI. (2015). Program on Technology Innovation: Technology Assessment of a Molten Salt Reactor Design, The Liquid-Fluoride Thorium Reactor (LFTR), EPRI Report 3002005460, Palo Alto, CA: Electric Power Research Institute.
 - EPRI. (2017a). Program on Technology Innovation: Early Integration: EPRI Workshop on Process Hazard Analysis to Probabilistic Risk Assessment for Advanced Reactors Proceedings: Vanderbilt University, Nashville, TN, July 18-19, 2017, EPRI Report 3002011916, Palo Alto, CA: Electric Power Research Institute.
 - EPRI. (2017b). Expanding the Concept of Flexibility for Advanced Reactors: Refined Criteria, a Proposed Technology Readiness Scale and Time-Dependent Technical Information Availability, EPRI Report No. 3002010479, Palo Alto, CA: Electric Power Research Institute.
 - EPRI. (2018). Program on Technology Innovation: Early Integration of Safety Assessment into Advanced Reactor Design—Preliminary Body of Knowledge and Methodology, EPRI Report 3002011801, Palo Alto, CA: Electric Power Research Institute.
 - EPRI. (2019). Program on Technology Innovation: Early Integration of Safety Assessment into Advanced Reactor Design—Project Capstone Report, EPRI Report 3002015752, Palo Alto, CA: Electric Power Research Institute.
 - EPRI. (2020). Compilation of Molten Salt Reactor Experiment (MSRE) Technical, Hazard, and Risk Analyses: A Retrospective Application of Safety-in-Design Methods, EPRI Report 3002018340, Palo Alto, CA: Electric Power Research Institute.
- Submittals to Regulator for Review (USNRC)
 - Southern Company/Electric Power Research Institute (2019). Molten Salt Reactor Experiment (MSRE) Case Study Using Risk-Informed, Performance-Based Technical Guidance to Inform Future Licensing for Advanced Non-Light Water Reactors, NRC Document identifier: ML19249B632.
 - General Atomics (2024). “Nuclear Technologies and Materials Advanced Reactor Concepts-20: Fast Modular Reactor Safety Approach and Probabilistic Risk Insights,” Document No. 30599200R0041, Revision 1. NRC Document identifier: ML24234A331.

References (2 of 3)

■ Peer-reviewed Journal Articles

- Chisholm, B., Krahn, S.L., & Fleming, K.N. (2020a). A Systematic Approach to Identify Initiating Events and its Relationship to Probabilistic Risk Assessment: Demonstrated on the Molten Salt Reactor Experiment, *Progress in Nuclear Energy*, 129, 103507.
- Chisholm, B., Krahn, S.L., & Sowder, A.G. (2020b). A Unique Molten Salt Reactor Feature – The Freeze Valve System: Design, Operating Experience, and Reliability, *Nuclear Engineering and Design*, 368.
- Harkema, M., Krahn, S., & Marotta, P. (2024a). Technical Brief: Safeguardability Analysis of a Molten Salt Sampling System Design, *Journal of Nuclear Engineering and Radiation Science*, 10, 039893.
- Harkema, M., Krahn, S., Marotta, P., Burak, A., Sun, X., Sabharwall, P. (2024). Development and Demonstration of a Prototype Molten Salt Sampling System, submitted to *Nuclear Technology*.
- Choi, H., Bolin, J., Gutierrez, O., Curiac, R., Alavai, M., Virgen, M., Chin, E., Beaver, J., Brocheny, P., Beausoleil, G., Yacout, A.M., Rodriguez, S., Corradini, M., Kim, D., Krahn, S.L., & Thornsby, E. (2024). “Progress in Fast Modular Reactor Conceptual Design,” *Nuclear Technology* 1-14. <https://doi.org/10.1080/00295450.2024.2319925>
- Ibrahim, I., Harkema, M., Krahn, S., Choi, H., Bolin, J., Thornsby, E. (2024). “Literature Review of Preliminary Initiating Events for a Gas-Cooled Fast Reactor Conceptual Design,” submitted to *Nuclear Technology*.
- Krahn, S., & Sowder, A. (2023). Public-Private Partnering in Nuclear Reactor Development – Historical Review and Implications for Today, *Journal of Nuclear Engineering and Radiological Sciences*, (10)3.

■ Doctoral Dissertations

- Chisholm, B. (2020). Development of a Technology-Inclusive Methodology to Analyze the Environmental, Safety, and Health Risks Associated with Advanced Nuclear Reactor Designs as Demonstrated on the Molten Salt Reactor Experiment, Unpublished Dissertation, Vanderbilt University, Nashville, TN.
- Harkema, M. (2024). Development and Demonstration of a Risk-Informed Molten Salt Sampling System for Molten Salt Reactors, Unpublished Dissertation, Vanderbilt University, Nashville, TN.

References (3 of 3)

Selected Conference Papers

- Chisholm, B., Krahn, S., Marotta, P., & Croff, A. (2017). Preliminary Risk Assessment of a Generalized Molten Salt Reactor Off-Gas System, *Transactions of the American Nuclear Society*, 117(1), pp. 221-224.
- Chisholm, B., Krahn, S., Afzali, A., & Sowder, A. (2018a). Application of a Method to Estimate Risk in Advanced Nuclear Reactors: A Case Study on the Molten Salt Reactor Experiment, presented at 14th International Conference on Probabilistic Safety Assessment and Management (PSAM 14), September 16-21, 2018, Los Angeles, CA.
- Chisholm, B., Krahn, S., Croff, A., Marotta, P., Sowder, A., & Smith, N. (2018b). A Technology Neutral Safety Assessment Tool for Advanced Nuclear Reactors: Preliminary Hazard Assessment and Component Reliability Database for the Molten Salt Reactor Experiment, presented at 2018 International Congress on Advances in Nuclear Power Plants (ICAPP 2018), April 8-11, 2018, Charlotte, NC.
- Chisholm, B., Krahn, S., Sowder, A., & Afzali, A. (2019). Development of a Methodology for Early Integration of Safety Analysis into Advanced Reactor Design, presented at 2019 International Topical Meeting on Probabilistic Safety Assessment and Analysis (PSA 2019), April 28-May 3, Charleston, SC.
- Harkema, M., Krahn, S., & Marotta, P. (2019). Evaluating the MSRE Sampler-Enricher: A Fresh Perspective, *Transactions of the American Nuclear Society*, 121(1), pp. 1193-1196.
- Harkema, M., Krahn, S., & Marotta, P. (2020a). Advanced Reactor System Design Insights from STAMP-based Analysis of Historical Parallels, presented at the 30th European Safety and Reliability Conference and the 15th Probabilistic Safety Assessment and Management Conference, November 1-5, 2020, Venice Italy.
- Harkema, M., Marotta, P., & Krahn, S. (2021). Fuel Salt Sampling and Enriching Technology Design Development—Project Update, *Transactions of the American Nuclear Society*, 124(1), pp. 465-467.
- Harkema, M., Krahn, S., Marotta, P., & Sowder, A. (2022a). Incorporation of Historical Information into the Advanced Reactor Design Process: A Case Study on the Development of a Molten Salt Sampling System, *Transactions of the American Nuclear Society*, 127(1), pp. 864-867.
- Harkema, M., Krahn, S., & Marotta, P. (2022b). Fuel Salt Sampling and Enriching Technology Design Development—Interfacing Systems Analysis and Project Update, *Transactions of the American Nuclear Society*, 126(1), pp. 688-691.
- Harkema, M., Marotta, P., & Krahn, S. (2022d). Model Refinement Studies for Molten Salt Freeze Port Conceptual Design Using COMSOL, *Transactions of the American Nuclear Society*, 126(1), pp. 87-90.
- Harkema, M., Krahn, S., & Marotta, P. (2023a). Expert Elicitation for Collection of Stakeholder Input for a Molten Salt Sampling System Design, *Transactions of the American Nuclear Society*, 129(1), pp. 796-799.
- Harkema, M., Krahn, S., & Marotta, P. (2023b). Fuel Salt Sampling and Enriching Technology Design Development—Failure Modes and Effects Analysis and Safeguardability Checklist Analysis, *Transactions of the American Nuclear Society*, 128(1), pp. 522-525.

Relevant ISO/IEC Standards

- ISO. (2019). Risk Management – Risk Assessment Techniques, ISO 31010, Geneva, Switzerland: International Standards Organization.
- ISO. (2018). Risk Management - Guidelines, ISO 31000, Geneva, Switzerland: International Standards Organization.
- ISO. (2022). Risk management—Vocabulary, ISO 31073, Geneva, Switzerland: International Standards Organization.
- ISO/IEC. (2018). Failure Modes and Effects Analysis (FMEA and FMECA), ISO/IEC-60812, Geneva, Switzerland: International Electrotechnical Commission.